

AUFBAUANLEITUNG

SPIELBETT 200/90

isle of dogs[®]

D · E · S · I · G · N

WUPPERTAL













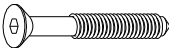

LEITER RECHTS MONTIERBAR



LEITER LINKS MONTIERBAR

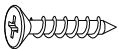
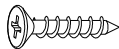
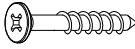
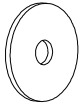
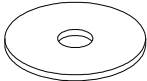
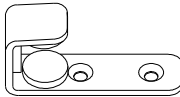

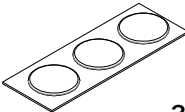
STÜCKLISTE

A	SCHRAUBE M6x100  10 stk	B	SCHRAUBE M6x50  3 stk	C	SCHRAUBE M6x15  2 stk
D	CONFIRMAT SCHRAUBE 70MM  8 stk	E	QUERMUTTERBOLZEN Ø10X14  10 stk	F	HOLZDÜBEL 10X50  8 stk
G	HOLZDÜBEL 8X16  4 stk	H	METALLSTIFT 10X50  4 stk	I	METALLSTIFT M6 10X42  1 stk
J	4X20  4 stk	K	4X25  16 stk	L	5X35  4 stk
M	UNTERLEGSCHIBE  2 stk	N	FILZ Ø40MM  4 stk	O	METALLHAKEN FÜR DIE LEITER  2 stk
P	ABDECKKAPPE 12MM  23 stk	R	ABDECKKAPPE  3 stk	S	GARDINENGLEITER  66 stk

LISTE DER EINZELTEILE

1 KURZES SEITENTEIL UNTEN LINKS

256 394

1 stk

2 KURZES SEITENTEIL UNTEN RECHTS

394 256

1 stk

3 HINTERES MITTELTEIL UNTEN

1 stk

4 TÖRCHEN VORNE

1 stk

5 RAD

1 stk

6 LATTENROST

1 stk

7 KURZES SEITENTEIL OBEN LINKS

256 224

1 stk

8 KURZES SEITENTEIL OBEN RECHTS

256 224

1 stk

9 MITTELTEIL OBEN HINTEN

1 stk

10 ABSTURZSICHERUNG OBEN VORNE

1 stk

11 VORDERES MITTELTEIL OBEN

1 stk

12 LEITER

1 stk

13 VERTIKALE STÜTZEN VOM HIMMELAUFSATZ

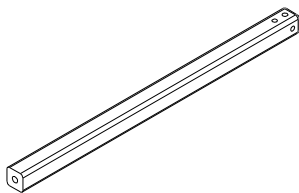

4 stk

14 LÄNGSVERSTREBUNG HIMMELAUFSATZ

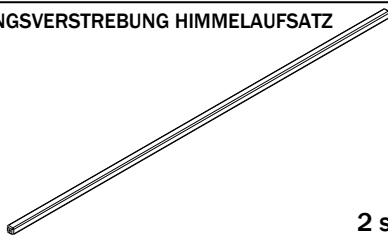

2 stk

15 QUERVERSTREBUNG HIMMELAUFSATZ

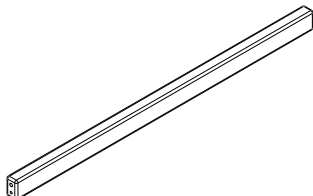

2 stk

16 ABDECKUNG PFOSTEN

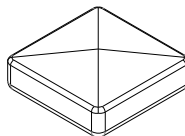

4 stk

SCHRITT 1

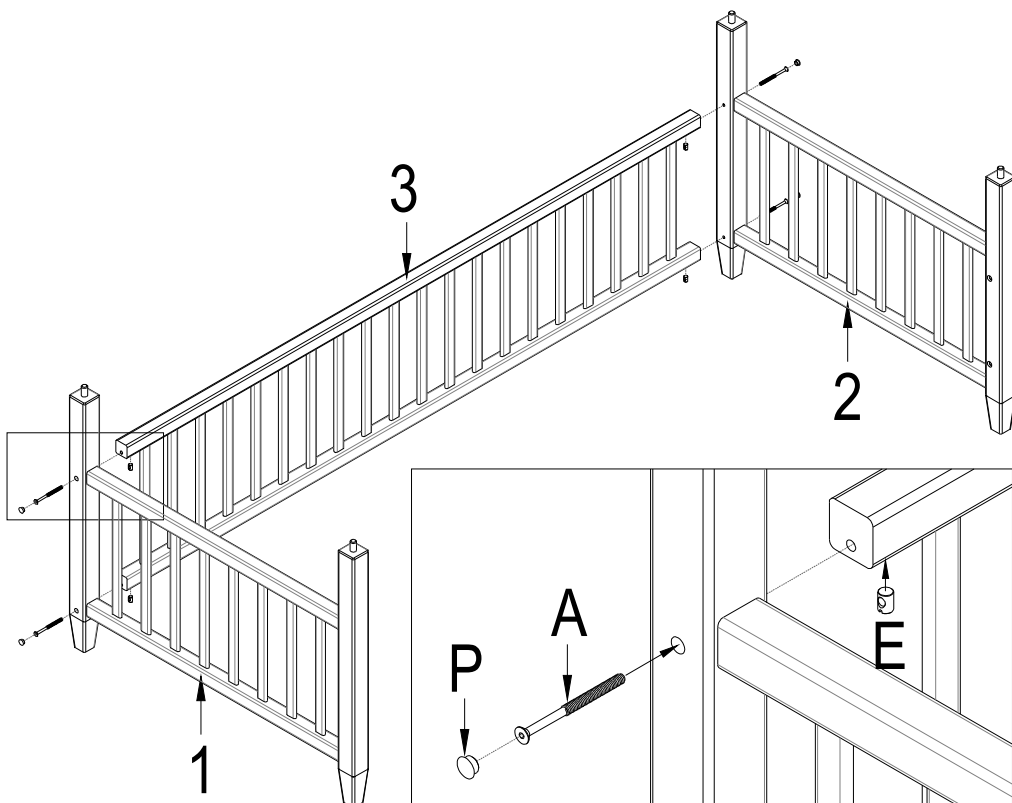

SCHRITT 2

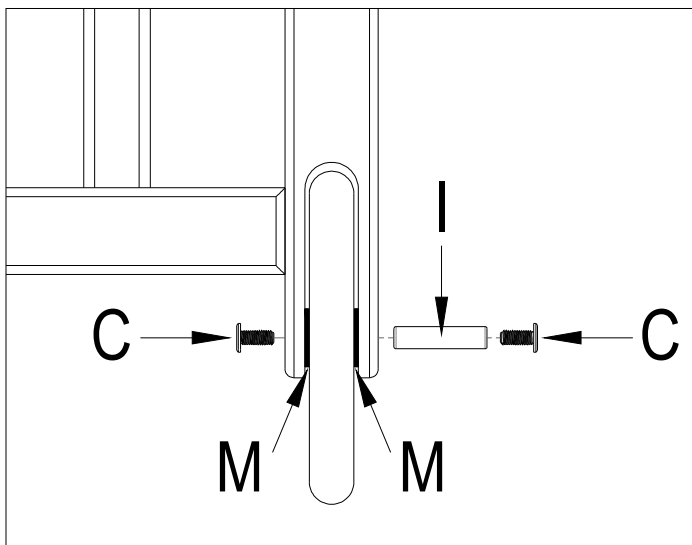
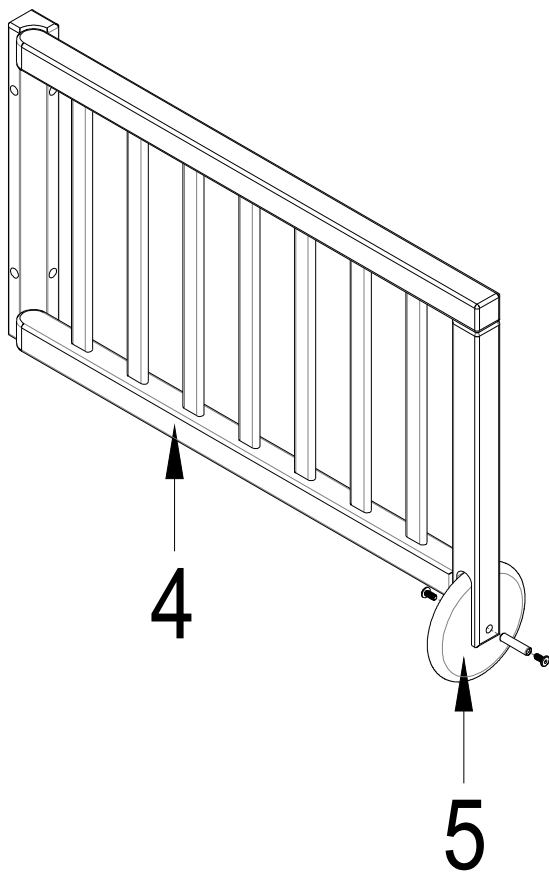

SCHRITT 3

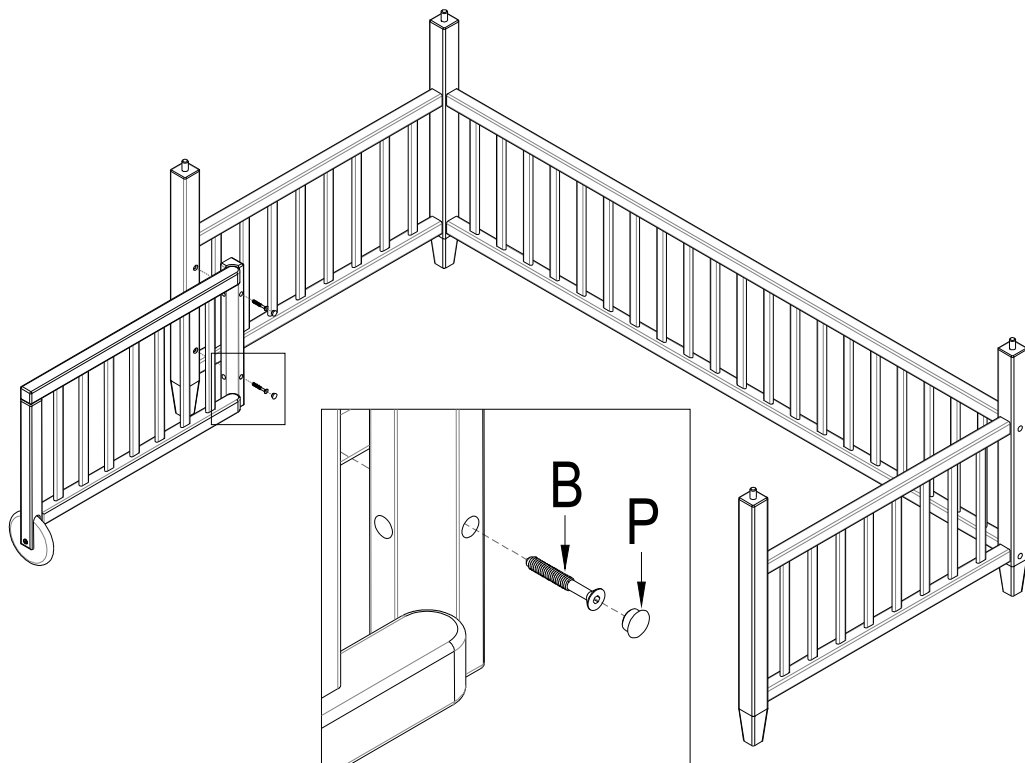

SCHRITT 4

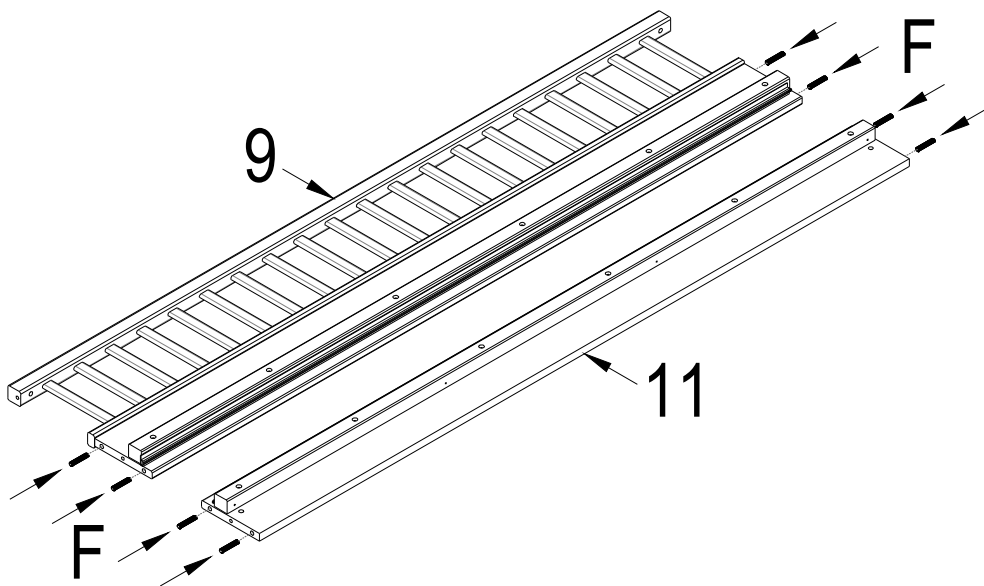

SCHRITT 5

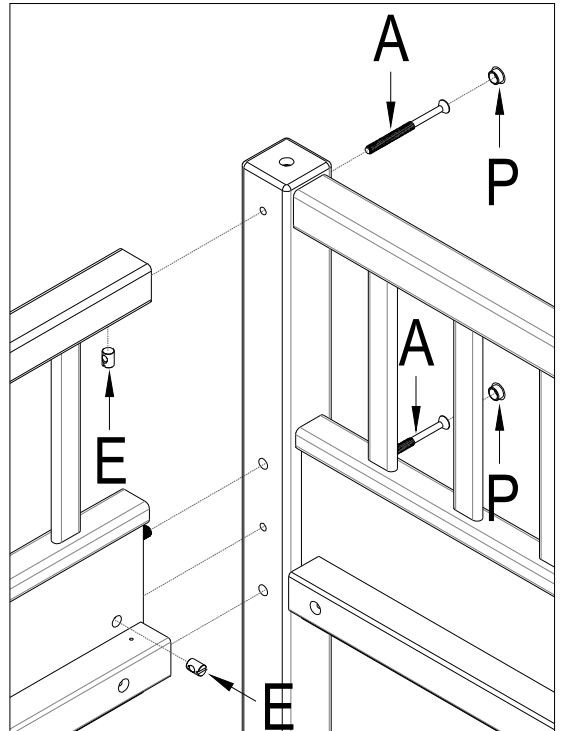
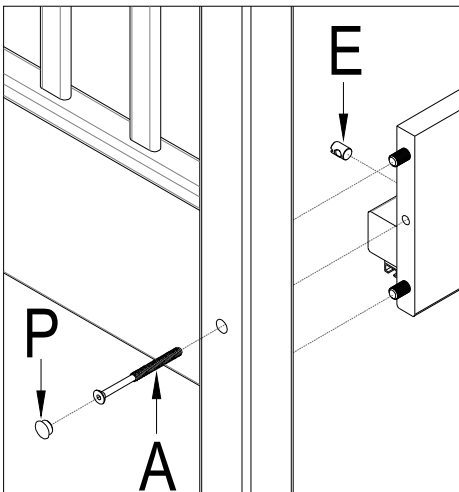
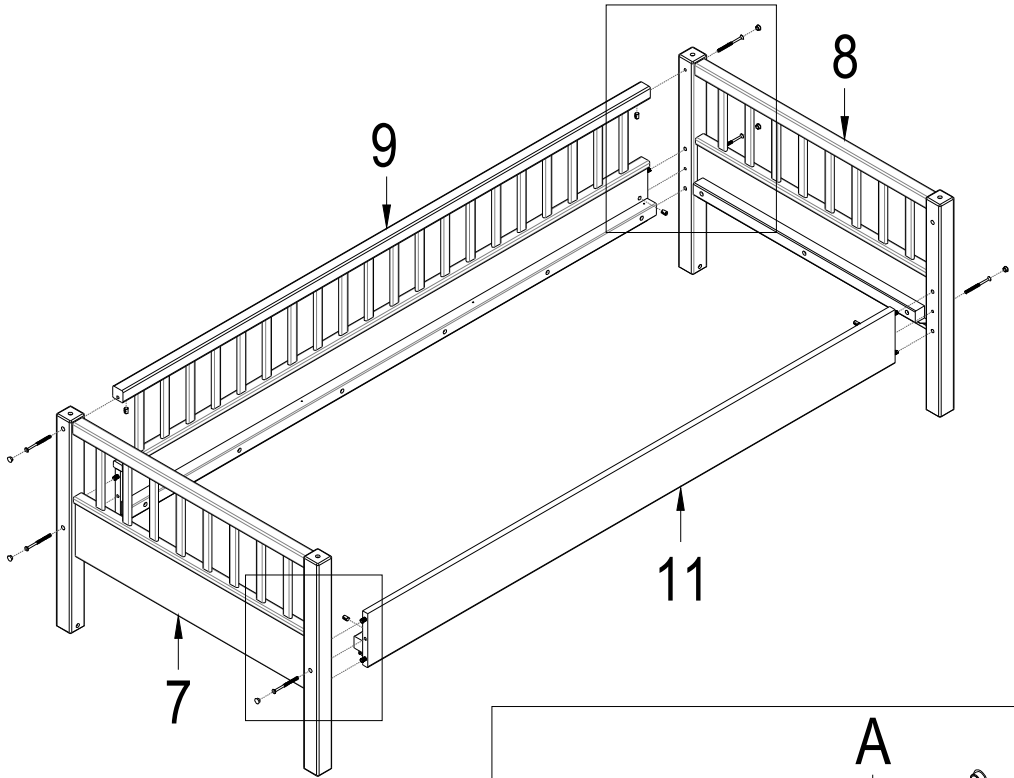

SCHRITT 6

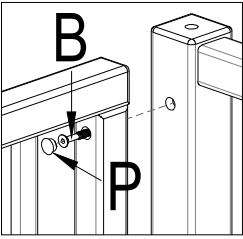

10

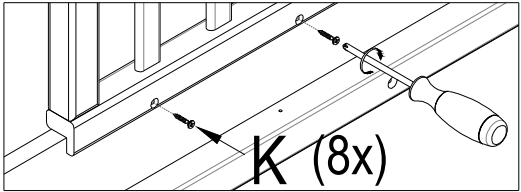
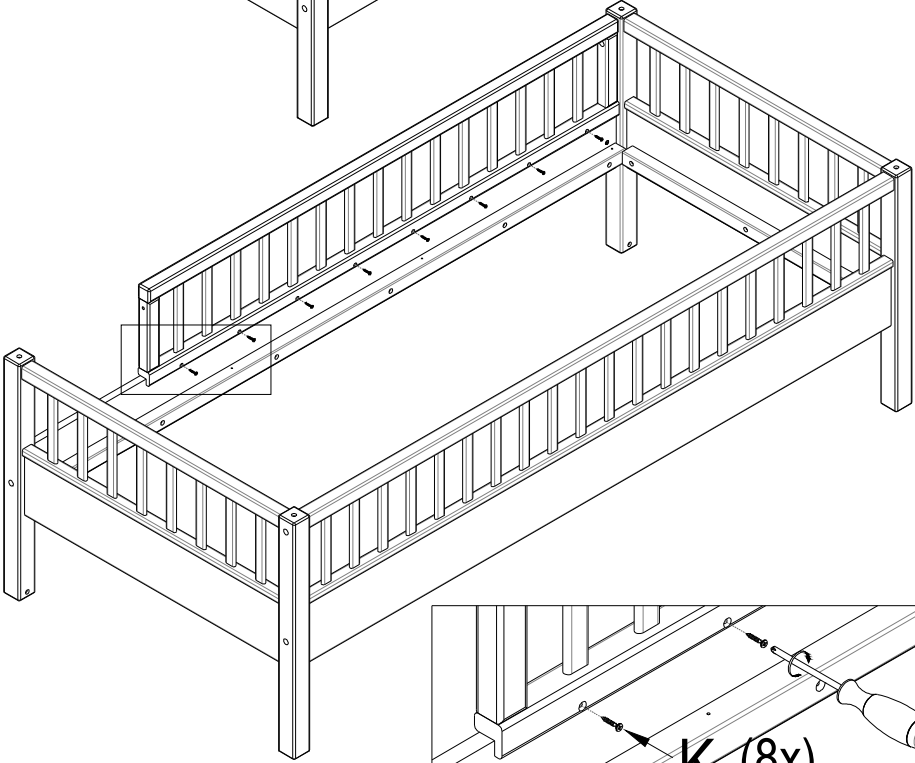
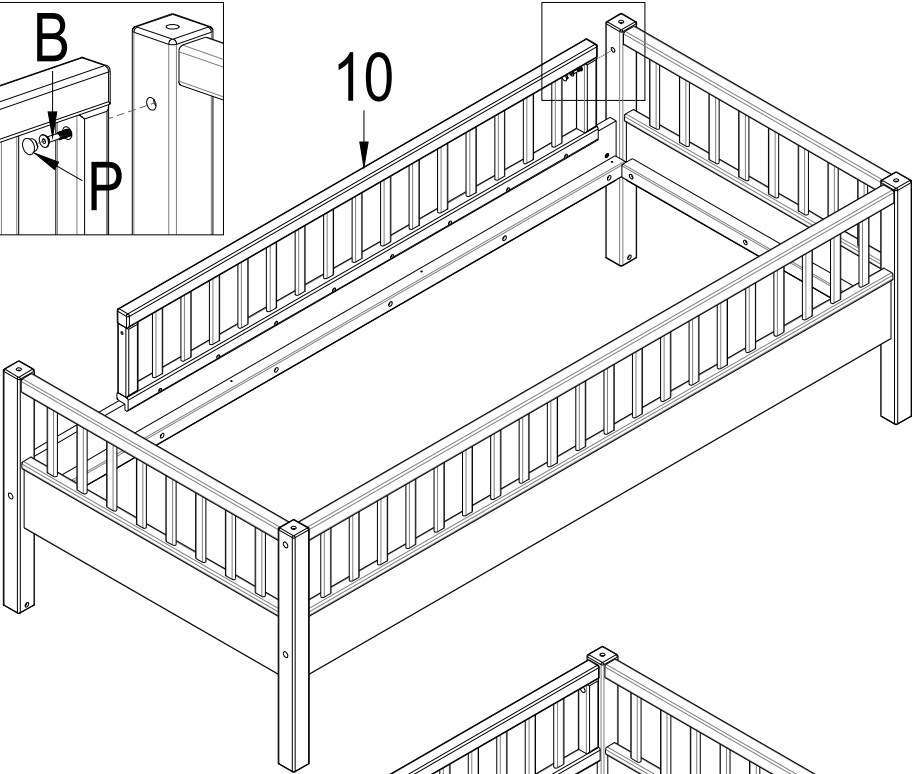

SCHRITT 7

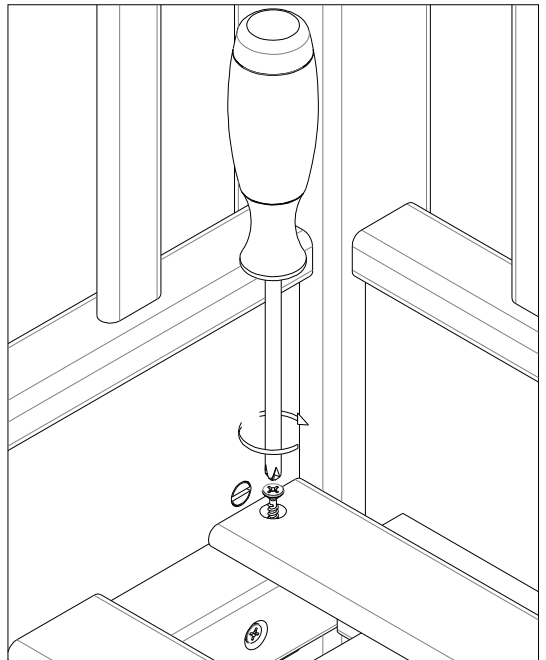
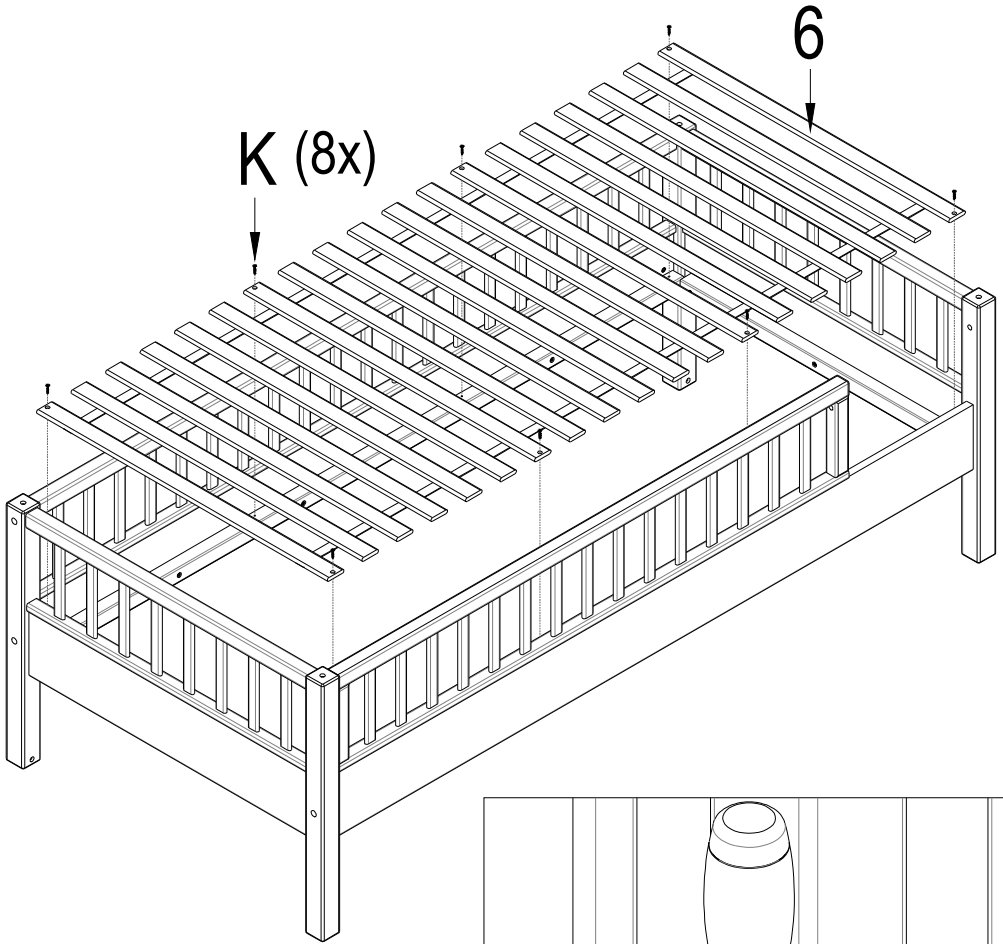

SCHRITT 8

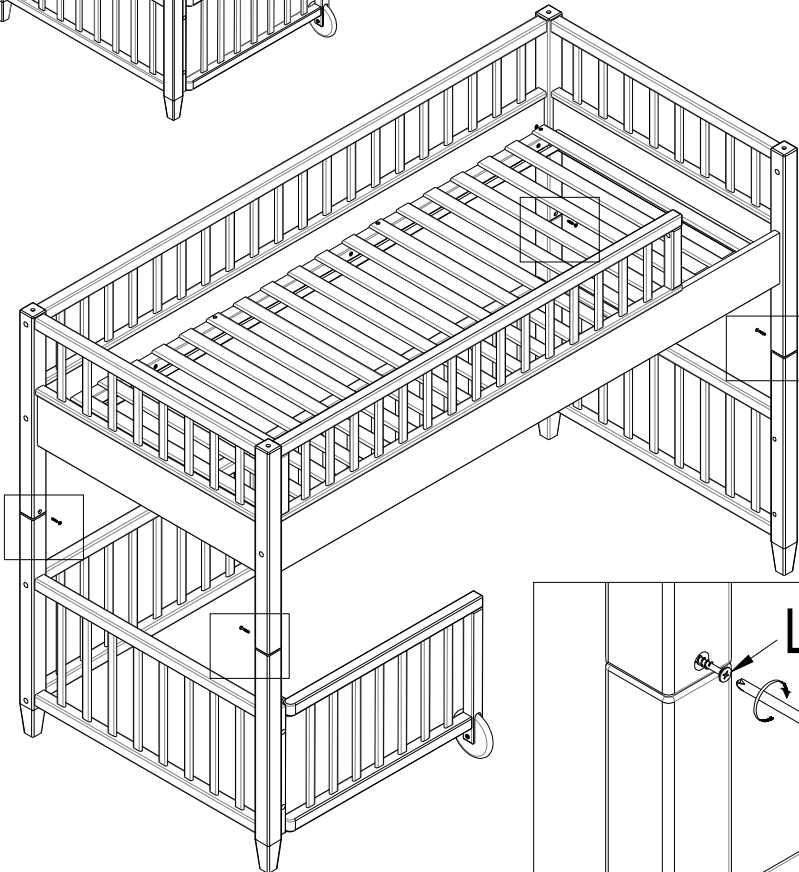
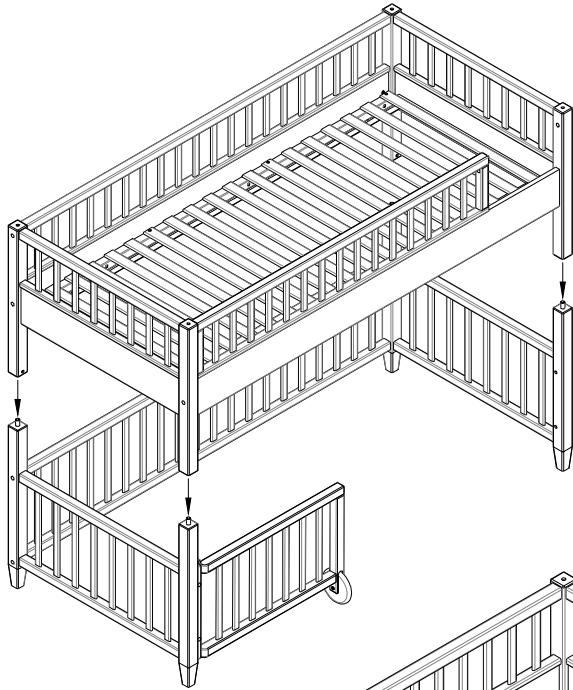

SCHRITT 9

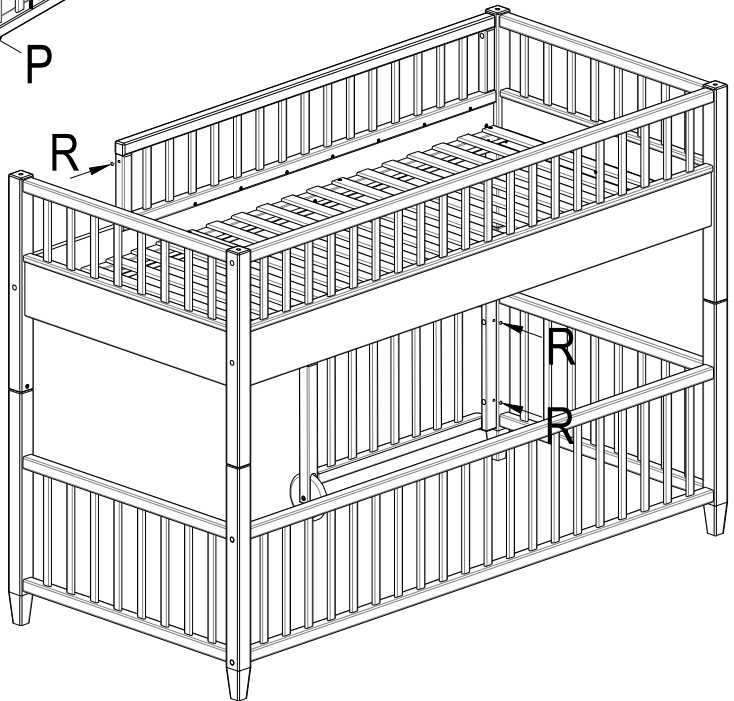
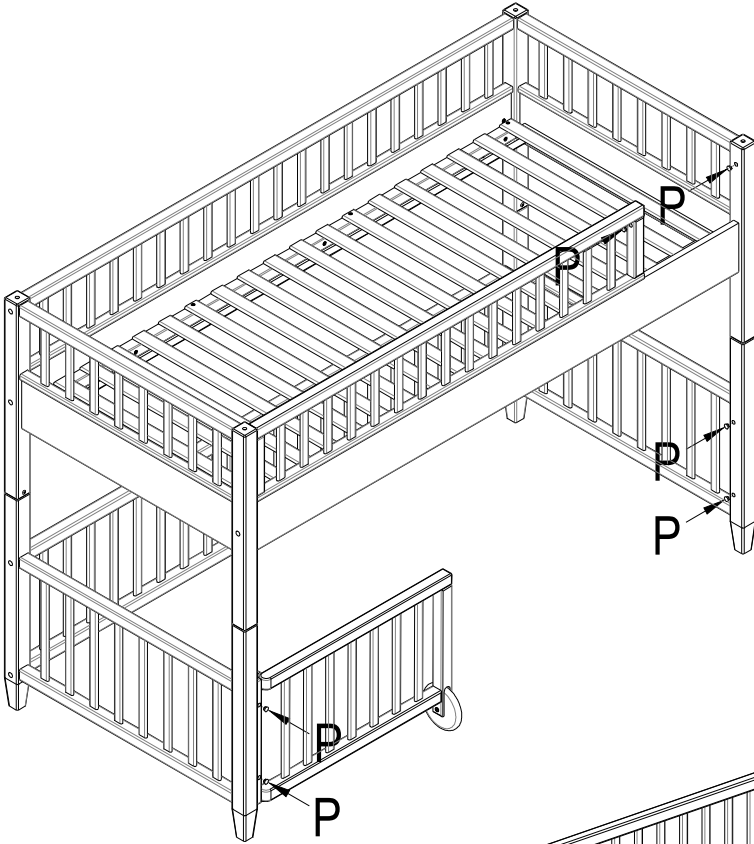

SCHRITT 10

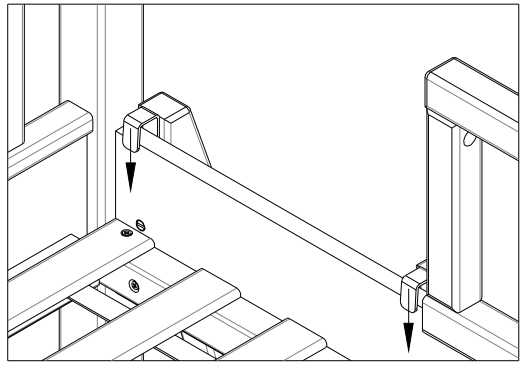
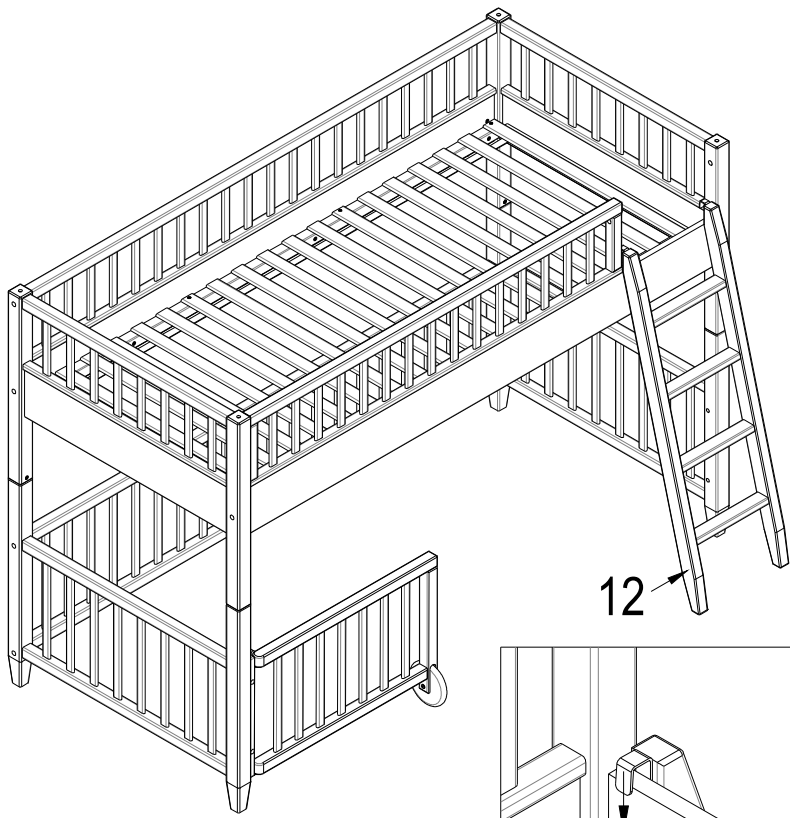
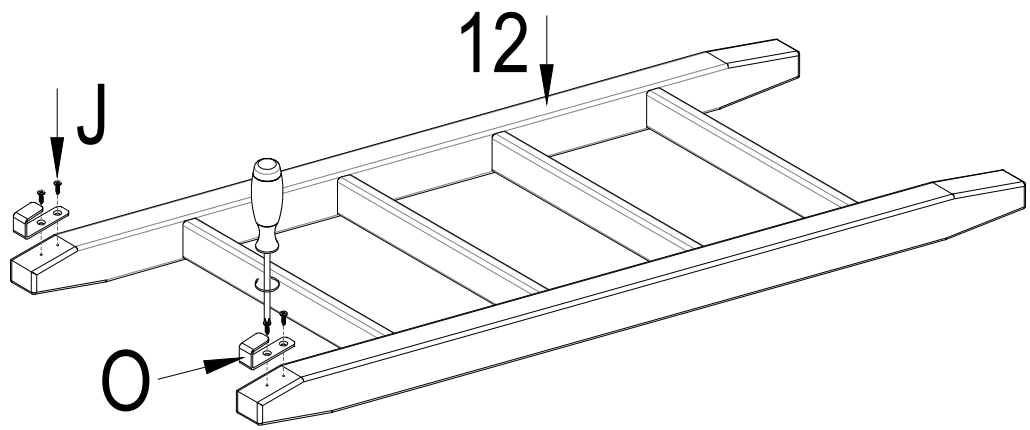

SCHRITT 11

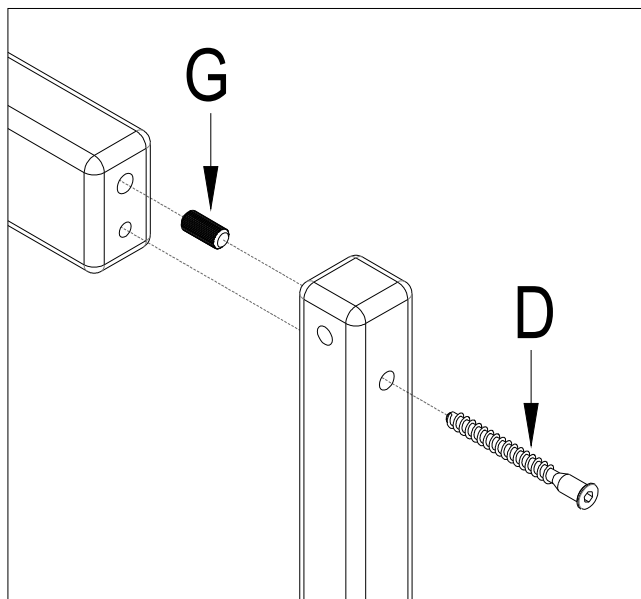
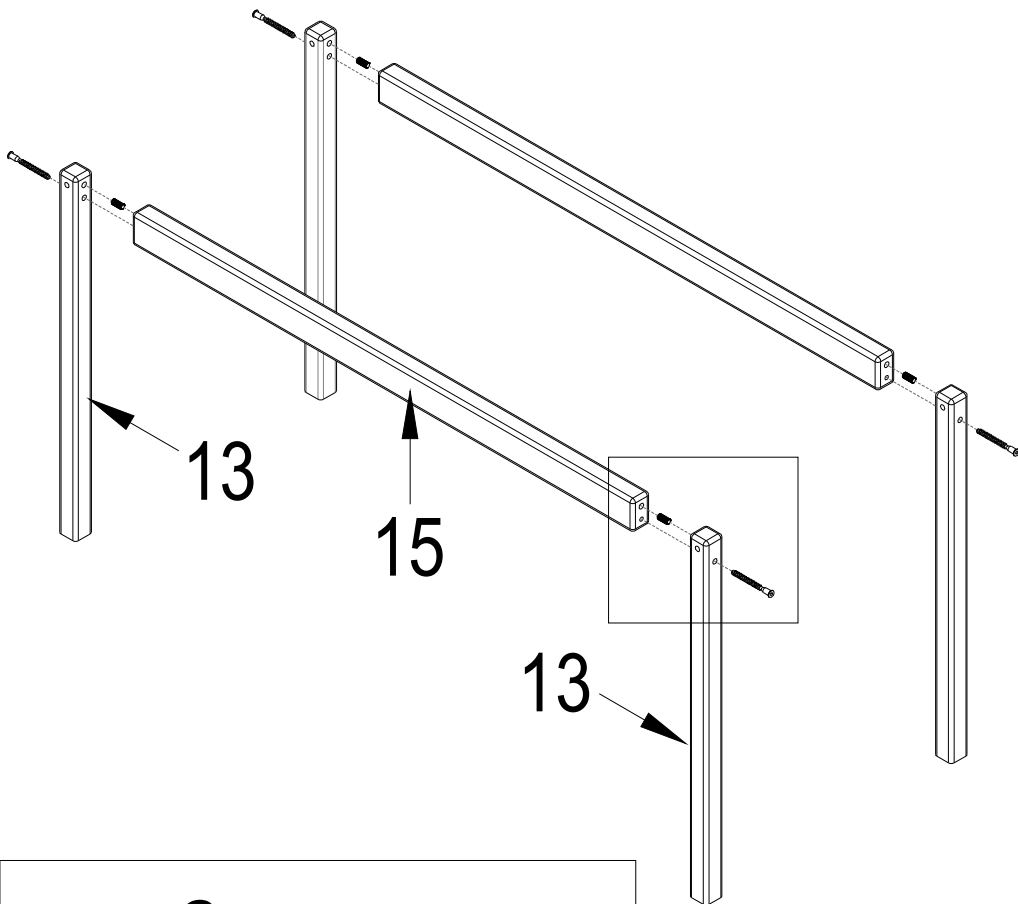

SCHRITT 12

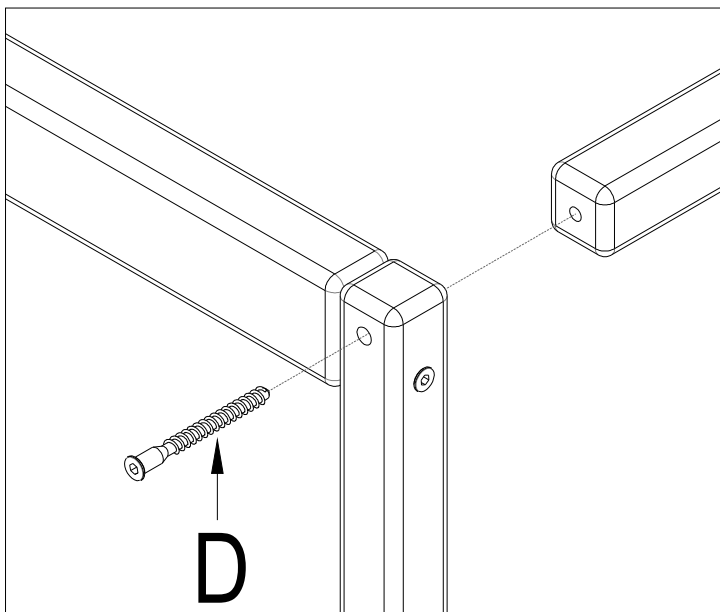
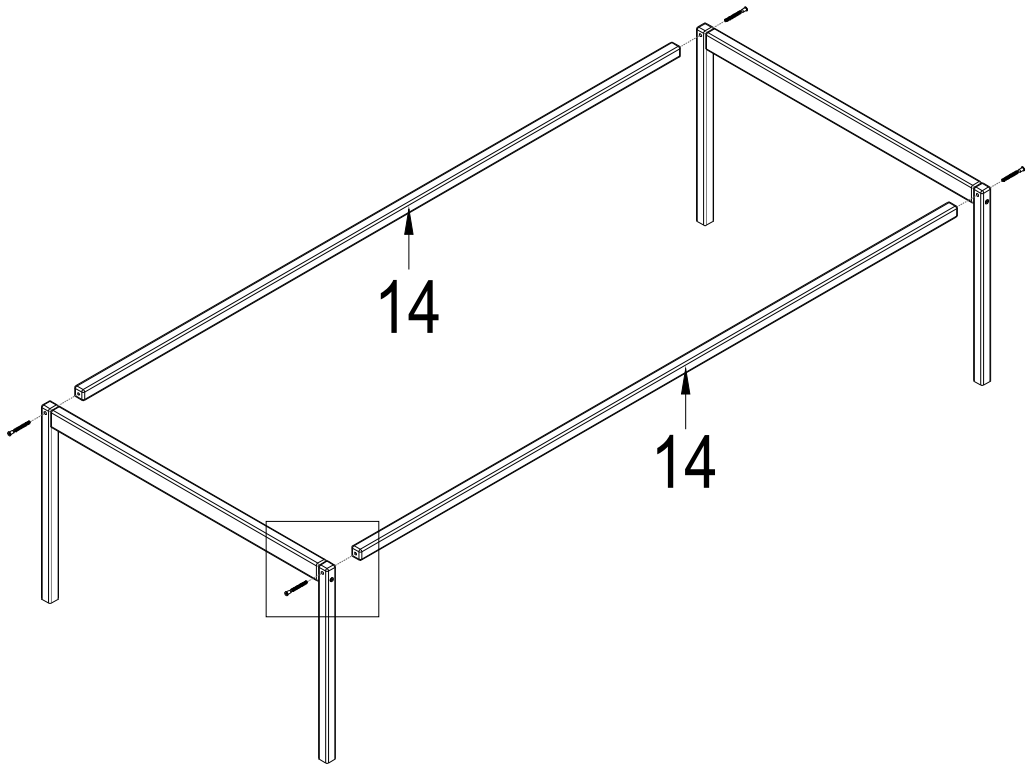

SCHRITT 13

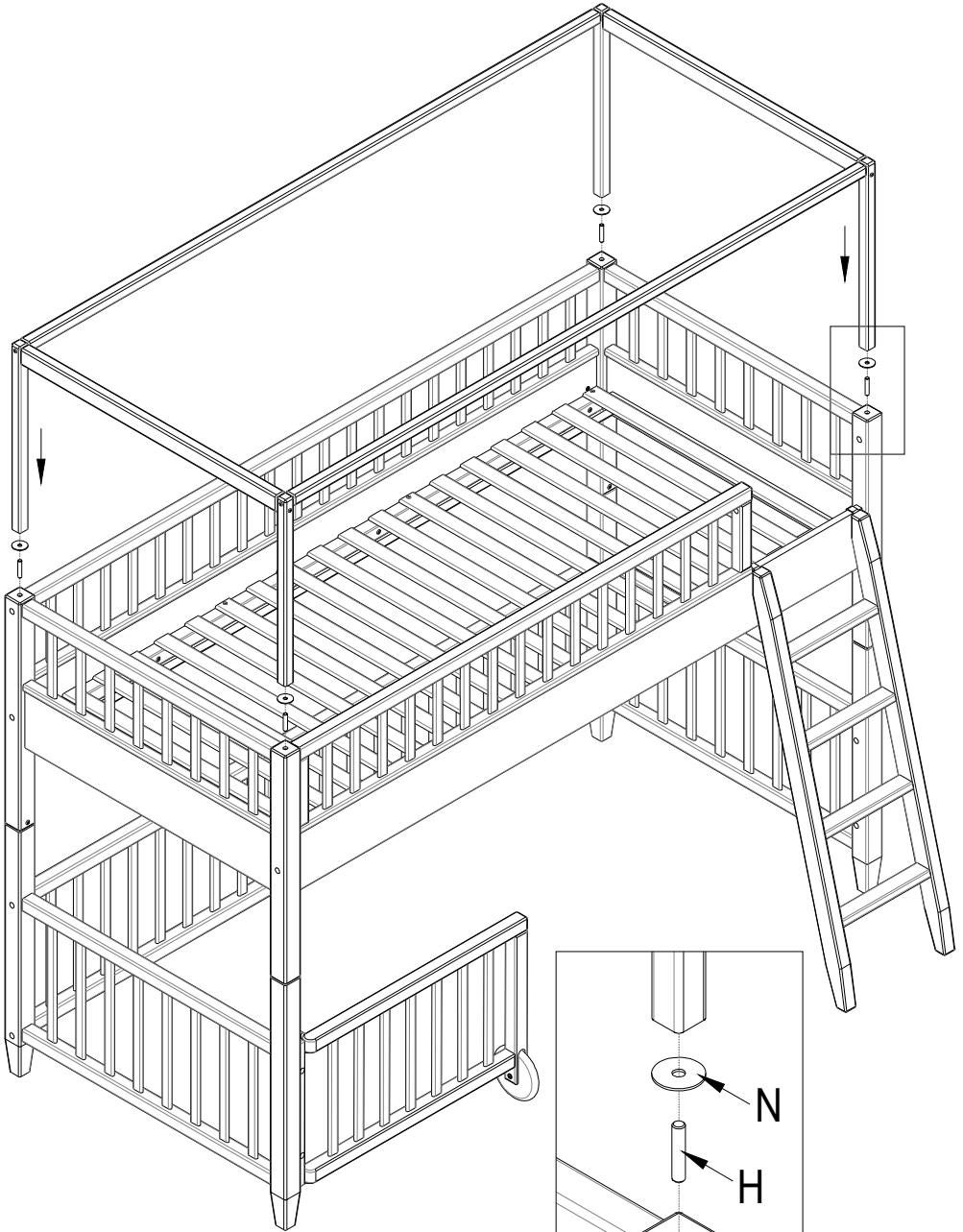

SCHRITT 14

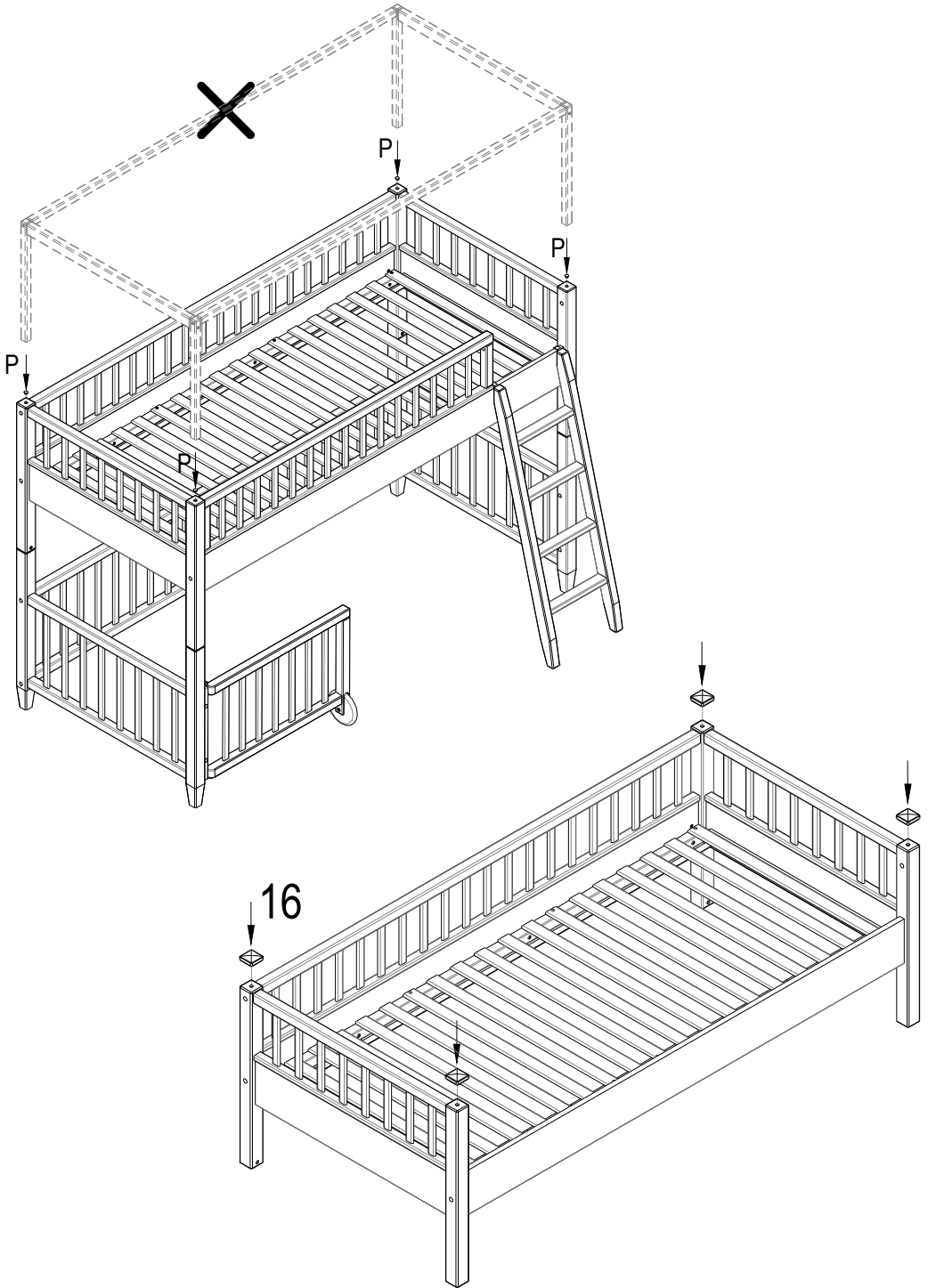

SCHRITT 15

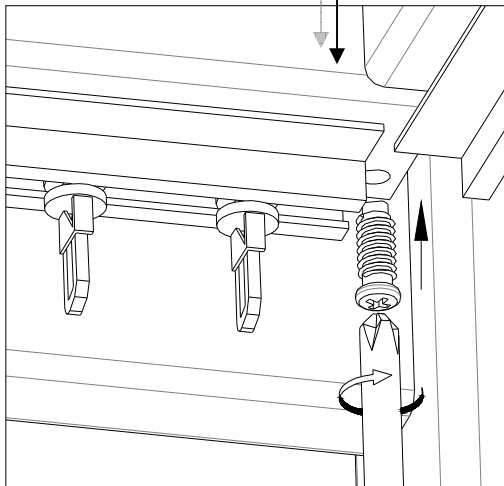
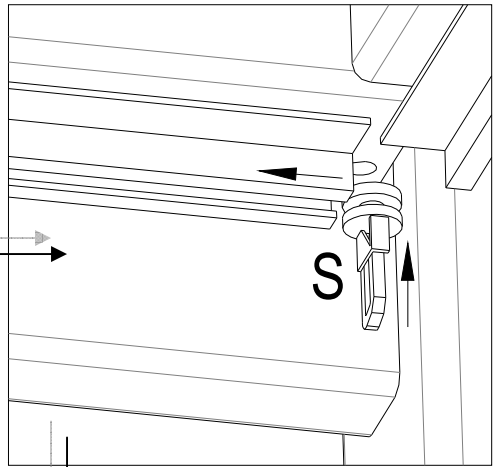
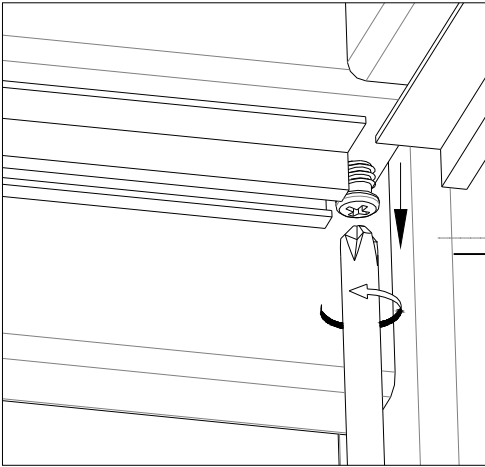

SCHRITT 16

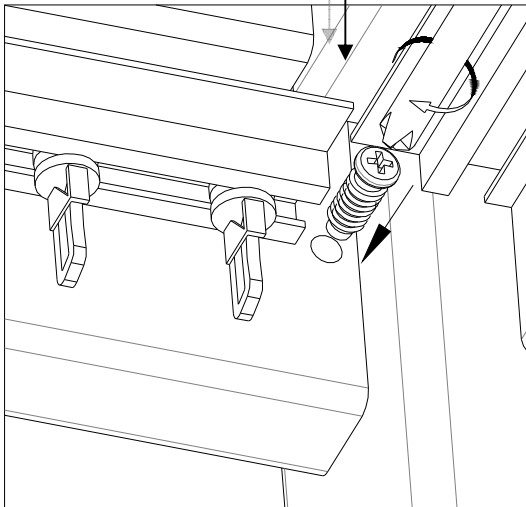
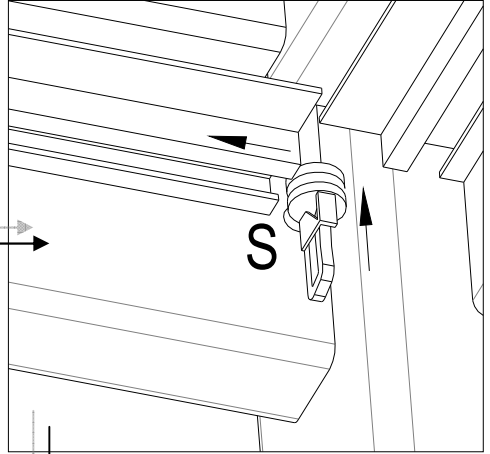
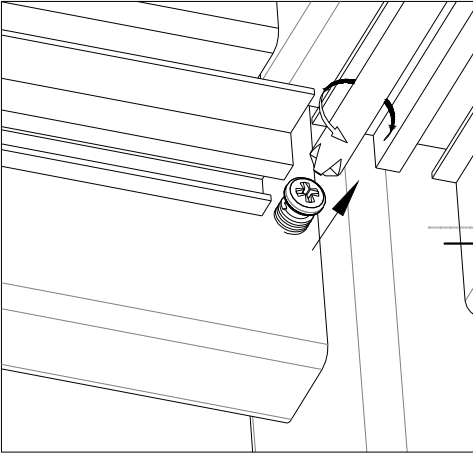

WARNHINWEIS: Kinder können zwischen Bett und Wand eingeklemmt werden. Um das Risiko schwerer Verletzungen zu vermeiden, darf der Abstand zwischen der oberen hinteren Absturzsicherung und der Wand nicht mehr als 7,5 cm betragen oder er muss größer sein als 23 cm .

WARNHINWEIS: Hochbetten und die oberen Betten von Etagenbetten sind wegen des Risikos von Sturzverletzungen nicht für Kinder unter sechs Jahren geeignet.

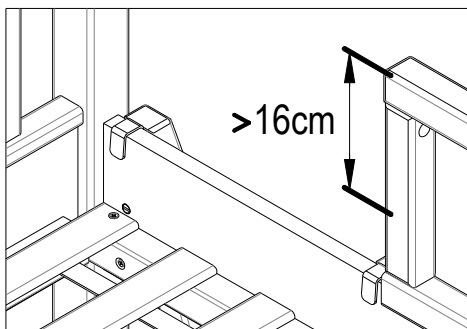

Der Mindestabstand von der Oberkante der Matratze bis zur Oberkante der Seitenteile muss 16 cm betragen!

WICHTIG ! – sorgfältig lesen – für spätere Einsichtnahme aufbewahren